

WOODWORKING FOR WILDLIFE

CAROLINA WREN NEST BOX

The Carolina wren is one of our most common and enjoyable songbirds. Its beautiful bubbling calls are a joy to hear during the summer.

Carolina wren nest boxes are most likely to be used if they are 5 to 10 feet above the ground and located under the eave of a building or in a tree. Wren boxes and gourds for purple martins are the only kind of bird house which can be free-hanging from an eye-screw. All other bird houses need to be firmly anchored.

Don't put a perch on the nest box. Perches invite sparrows to try using the nest. If you have a perch on a wren house, take it off. The entrance hole for a wren house should be 1 inch in diameter. Carolina wren holes are too small for house sparrows and European starlings to use.

As soon as one family of wrens leaves a house, clean it out so another brood of young can be raised.



1/4" Holes for Ventilation

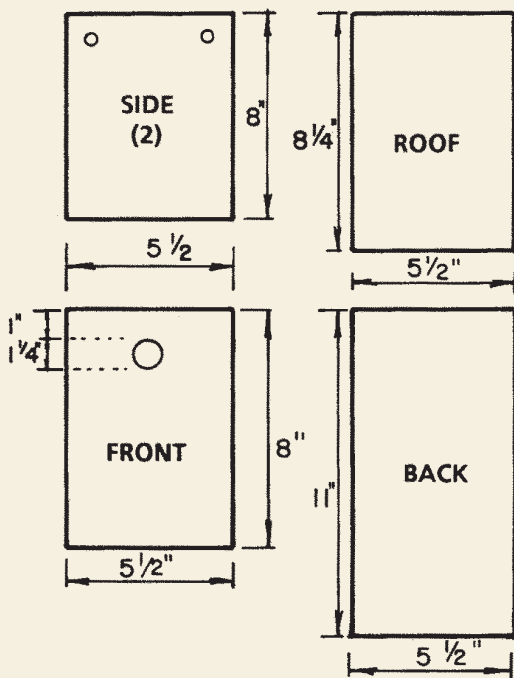

1/4" Holes for Drainage

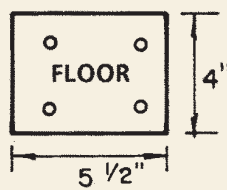

NOTE: ENTRANCE HOLE DIAMETER IS 1 1/4"

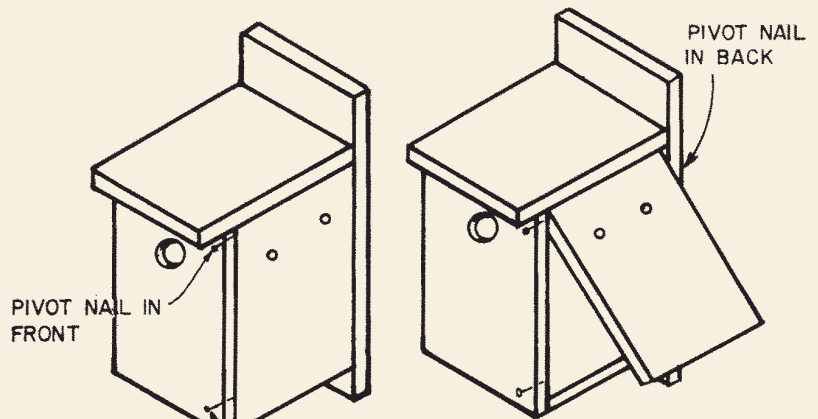

NAIL OR SCREW HOLDS SIDE CLOSED.

TWO "PIVOT" NAILS ALLOW SIDE TO SWING OUT FOR CLEANING.

USE ONE NAIL AT BOTTOM TO CLOSE SIDE.

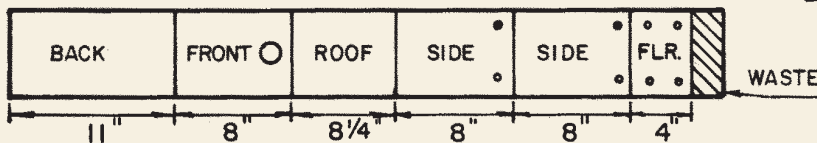

LUMBER:
ONE 1" x 6" x 4' 0"